

	<p><b>BUILDING RESEARCH INSTITUTE</b> European Notified Body № 1488</p>
  <p>AB 023</p>	<p><b>GROUP OF TESTING LABORATORIES</b> accredited by Polish Center for Accreditation</p> <p>accreditation certificate № AB 023</p>

**LK**

**TEST REPORT № LK02-0893/11/R19NK**

**Page 1/13**

**Building Structures Laboratory**

Address: 02-656 Warszawa, ul. Ksawerów 21      tel. 22 56-64-260      fax. 22 56-64-215

**Customer**                      ALIPLAST Sp. z.o.o.  
ul. Waclawa Moritza 3,  
20-276 Lublin - Poland

**Object of tests**              Fixed Light  
made of aluminium profiles **ECOFUTURAL EF** with additional mullion

**Accepted for testing**      06.05.2011 with the protocol LK02-0893/11/R19NK/Not  
in accordance with the procedure no. 18

**Test period**                      06.05.2011

**Test methods:**

Initial type testing (ITT) – AoC system 3 PN-EN 14351-1+A1: 2010

PN-EN 1026:2001      Windows and doors – Air permeability – Test method  
PN-EN 1027:2001      Windows and doors – Watertightness – Test method  
PN-EN 12211:2001      Windows and doors – Resistance to wind load - Test method

**Additional properties**

PN-EN 13049:2004      Windows-Soft and heavy body impact-Test method, safety requirements and classification

The test equipment used comply with the above-mentioned standards.

## 1 The scope of tests

The scope of initial type testing covered the verification of:

- air permeability,
- watertightness,
- resistance to wind load.

The scope of additional tests covered the verification of:

- impact resistance.

Personnel executing the test:

eng. Marcin Dmochowski,

Daniel Kuna

- Instytut Techniki Budowlanej, Laboratorium Konstrukcji i Elementów Budowlanych ZLB,

## 2 Test specimen (identification)

The object of the tests was the Fixed light; dimensions S x H = 3900 x 2800 mm – 1 element assembled in 2011 r.

The information about sampling of the specimen by right of ALIPLAST Sp. z.o.o ., ul. Wacława Moritza 3, 20-276 Lublin - Poland sampling report:

**Manufacturer:** ENERGOMET Piotr Wolski, Prawiedniki-Kolonia 62,20-515 Lublin  
- POLAND

**Place of sampling:** ENERGOMET Piotr Wolski, Prawiedniki-Kolonia 62,20-515 Lublin  
- POLAND

**Number of samples:** 1

**Description of the sample:** Fixed light,  
dimensions 3900 x 2800 mm,  
made of aluminium profiles **ECOFUTURAL EF**.

**Date of sampling:** may, 2011

### Used materials

The scheme of the window is shown on figure 1. Components (profiles, gaskets) are shown on figures 3÷7.

Fixed light infilling consisted of 6/16/33.1 insulating glass unit.

Drainage: frame - 4x(20x12mm), transom 2x(20x12mm),

EPDM gaskets:

- external gaskets - ACFT031N, ACVG31, ACSP031,
- internal gaskets - ACFT033N, ACSP034, ACVG34,

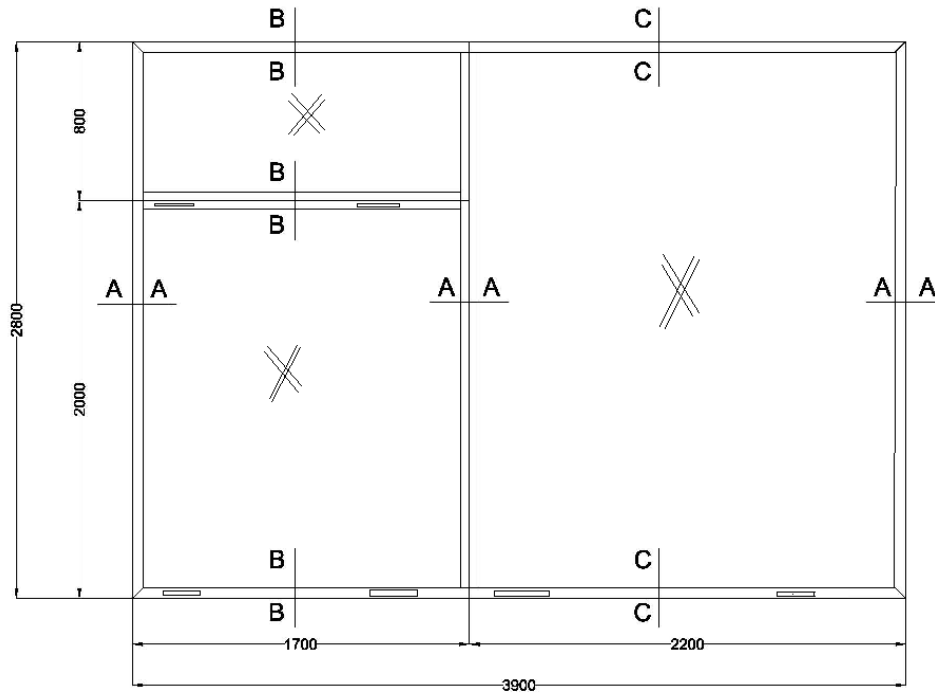

Fig. 1 Scheme of testing Fixed light



### przekrój B-B

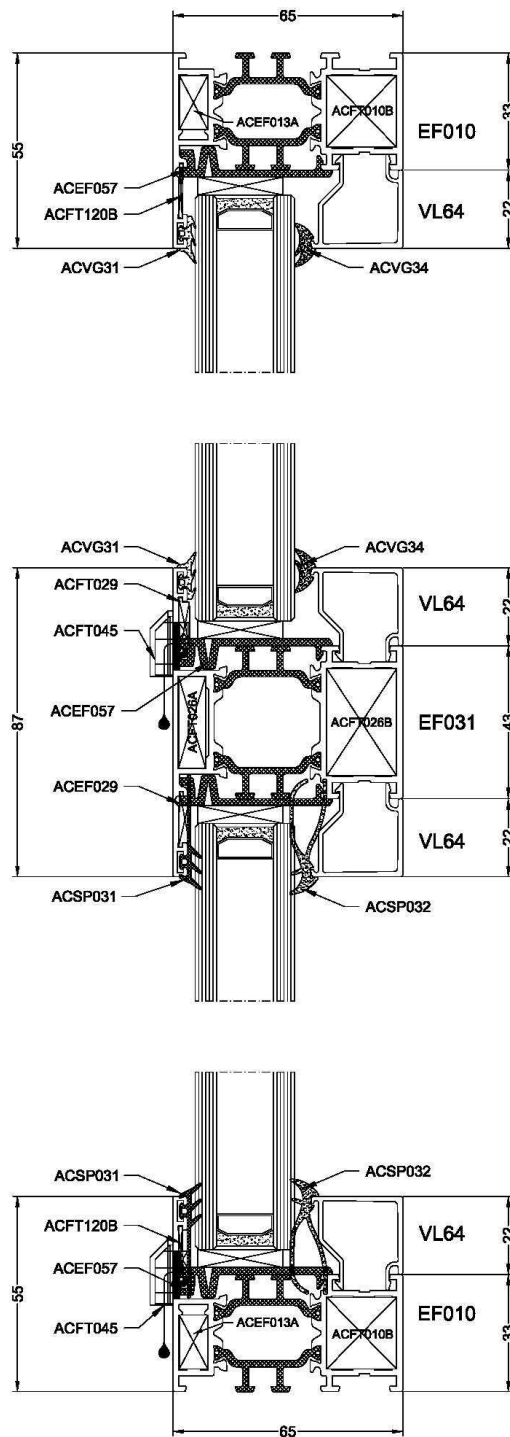

Fig. 3 Cross-section B-B

## przekrój C-C

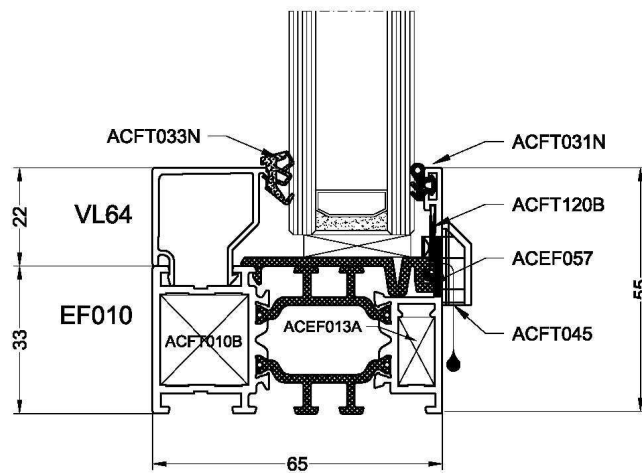
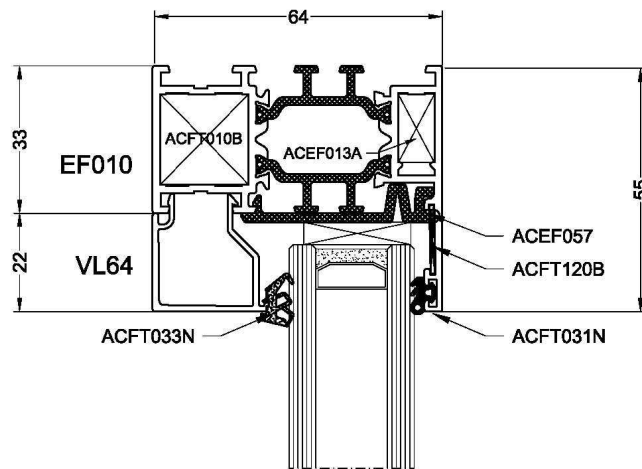

Fig. 4 Cross-section C-C

### 3 The methods and results

#### 3.1 Air permeability (before the test of resistance to wind load)

The test was carried out in accordance with the PN-EN 1026: 2001.

specimen area	10,9m <sup>2</sup>	joint length	21,2 m	temp.	19 °C	humidity	28%	atm. pressure	1013hPa
---------------	--------------------	--------------	--------	-------	-------	----------	-----	---------------	---------

**Tab. 1 Air permeability Fixed light 2 positive test pressure**

Air flow		Value of air permeability at pressure, Pa							
		50	100	150	200	250	300	450	600
overall	m <sup>3</sup> /h	2,2	5,6	4,6	7,8	8,1	8,5	13,9	17,0
in relation to joint length	m <sup>3</sup> /hm	0,10	0,26	0,22	0,37	0,38	0,40	0,66	0,80
in relation to surface	m <sup>3</sup> /hm <sup>2</sup>	0,20	0,51	0,42	0,71	0,74	0,78	1,27	1,56
air inf. coefficient , a	m <sup>3</sup> /(mhdaPa <sup>2/3</sup> )	0,04	0,06	0,04	0,05	0,04	0,04	0,05	0,05

**Tab. 2 Air permeability Fixed light 2 negative test pressure**

Air flow		Value of air permeability at pressure, Pa							
		50	100	150	200	250	300	450	600
overall	m <sup>3</sup> /h	3,5	4,5	5,5	6,2	7,3	12,8	16,7	11,6
in relation to joint length	m <sup>3</sup> /hm	0,17	0,21	0,26	0,29	0,34	0,60	0,79	0,55
in relation to surface	m <sup>3</sup> /hm <sup>2</sup>	0,32	0,41	0,50	0,57	0,67	1,17	1,53	1,06
air inf. coefficient , a	m <sup>3</sup> /(mhdaPa <sup>2/3</sup> )	0,06	0,05	0,04	0,04	0,04	0,06	0,06	0,04

**Tab. 3 Air permeability Fixed light 2 numerical average**

Air flow		Value of air permeability at pressure, Pa							
		4,0	6,0	7,2	8,7	11,2	11,8	15,1	18,3
overall	m <sup>3</sup> /h	2,9	5,1	5,1	7,0	7,7	10,7	15,3	14,3
in relation to joint length	m <sup>3</sup> /hm	0,13	0,24	0,24	0,33	0,36	0,50	0,72	0,68
in relation to surface	m <sup>3</sup> /hm <sup>2</sup>	0,26	0,46	0,46	0,64	0,71	0,98	1,40	1,31
air inf. coefficient , a	m <sup>3</sup> /(mhdaPa <sup>2/3</sup> )	0,04							

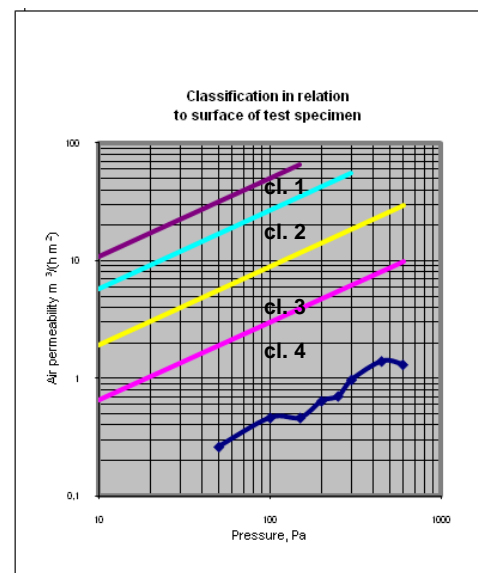
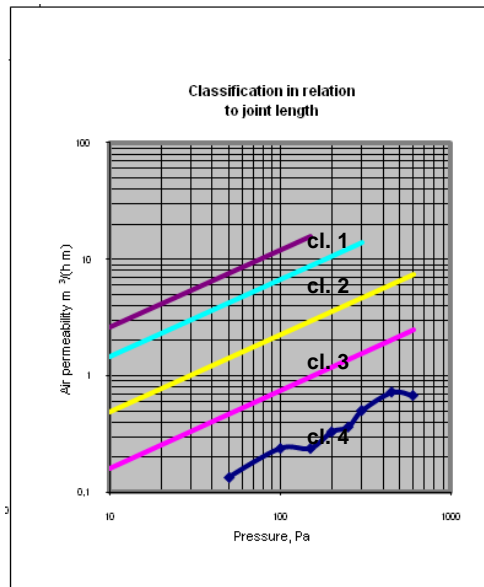

Classification in relation to joint length	Class 4
Classification in relation surface of test specimen	Class 4
<b>PN-EN 12207:2001 overall classification</b>	<b>Class 4</b>

### 3.2 Watertightness

The test was carried out in accordance with the PN-EN 1027: 2001, method 1A. Test results are shown in table no. 4.

Tab. 4 Watertightness

Pressure, Pa	Testing time, min	Remarks and observations	Pressure, Pa	Testing time, min	Remarks and observations
0	15	no leakage	750	5	leakage – 2 min.
50	5	no leakage	900	-	-
100	5	no leakage	1050	-	-
150	5	no leakage	1200	-	-
200	5	no leakage	1350	-	-
250	5	no leakage	1500	-	-
300	5	no leakage	-	-	-
450	5	no leakage			
600	5	no leakage			

PN-EN 12208:2001 classification

class 9A (600Pa)

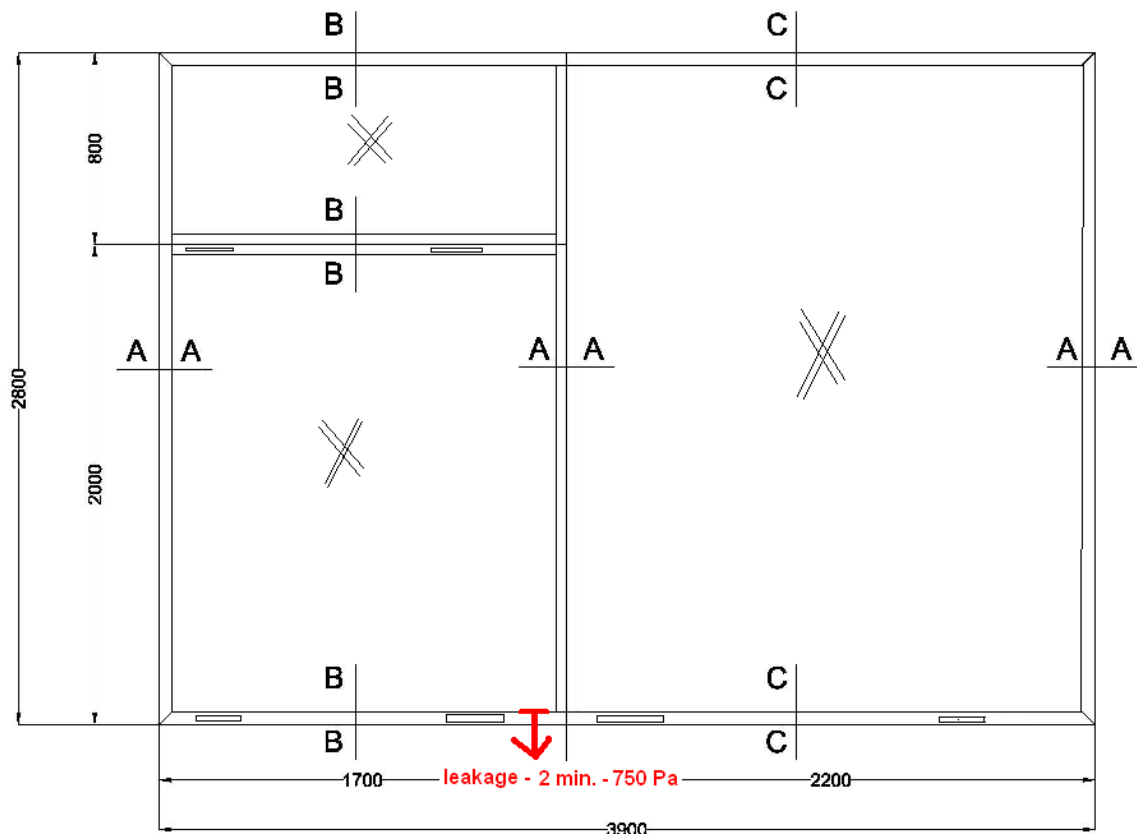

Fig. 5 Fixed light - leakage

### 3.3 Resistance to wind load

The test was carried out in accordance with the PN-EN 12211:2001.

#### Measurement of deflection with P1

The spacing of measurement points is presented on figure no. 6.

Test results are shown in tables no. 5 and 6.

**Tab. 5** Fixed light 2 pressure

Load, Pa	200	400	600	800	1200	1600	2000	0
Point 1	0,9	2,4	3,7	5,2	7,0	8,4	---	0,7
Point 2	2,5	5,5	8,0	10,5	15,5	21,7	---	2,0
Point 3	0,7	1,4	3,0	4,0	5,6	7,2	---	0,9
Displacement, mm	1,7	3,6	4,7	5,9	9,2	13,9	---	0,0
Deflection 1/	1/1647	1/778	1/602	1/475	1/304	1/201	---	---
Point 4	2,1	4,3	3,0	8,8	12,8	16,9	---	1,9
Point 5	2,0	4,2	6,7	8,8	13,0	17,6	---	1,6
Point 6	0,4	0,9	1,7	2,3	3,1	3,9	---	0,6
Displacement, mm	0,8	1,6	4,4	3,3	5,1	7,2	---	0,4
Deflection 1/	1/2187	1/1025	1/377	1/505	1/325	1/228	---	---

**Tab. 6** Fixed light 2 suction

Load, Pa	200	400	600	800	1200	1600	2000	0
Point 1	0,3	0,6	1,1	1,4	2,1	3,5	5,5	1,1
Point 2	0,7	1,7	2,9	3,9	6,4	10,0	15,6	1,6
Point 3	0,1	0,4	1,0	1,2	2,1	3,4	5,3	1,0
Displacement, mm	0,5	1,2	1,9	2,6	4,3	6,6	10,2	---
Deflection 1/	1/5600	1/2333	1/1514	1/1077	1/651	1/427	1/275	---
Point 4	0,4	1,4	2,8	4,2	6,9	9,4	11,7	0,6
Point 5	0,5	1,9	3,5	5,1	8,3	11,3	14,5	0,9
Point 6	0,1	0,3	0,6	0,8	1,5	2,4	2,7	0,4
Displacement, mm	0,3	1,1	1,8	2,6	4,1	5,4	7,3	0,4
Deflection 1/	0,0	0,0	0,0	0,0	0,0	0,0	0,0	---
Point 4	1/6560	1/1562	1/911	1/631	1/400	1/304	1/225	---

PN-EN 12210:2001 classification

**C3 (1200 Pa)/B4 (1600Pa)**

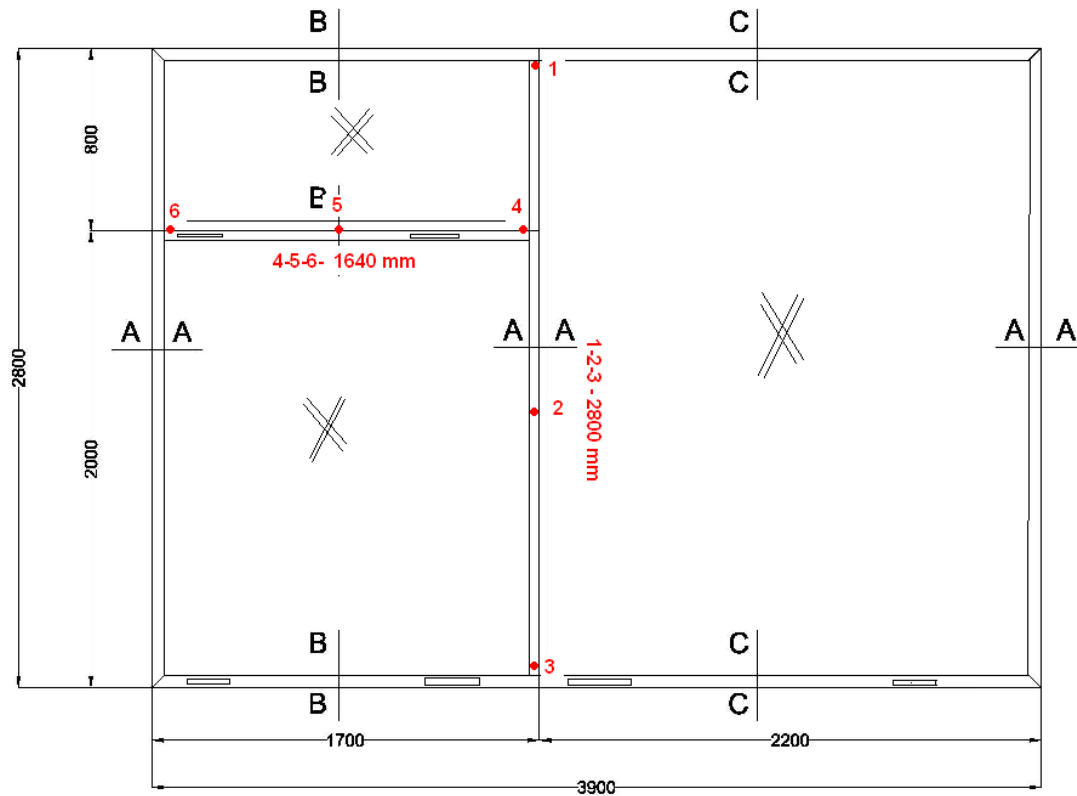

Fig. 6 Spacing of measurement points

### **Repeated load P2**

The window was loaded with 50 pressure/suction cycles at:

- ±600 Pa for class C3,
- ±800 Pa for class B4.

After test no visible changes were observed.

### **Safety test P3**

The window was subjected to a brief safety test:

- pressure of 1800 Pa and suction of 1200 Pa – for class C3,
- pressure of 2400 Pa and suction of 1800 Pa – for class B4.

After test no visible changes were observed.

### **3.4 Air permeability (after the test of resistance to wind load)**

The test was carried out in accordance with the PN-EN 1026: 2001.

Test results are shown in tables no. 7÷9.

specimen area	10,9m <sup>2</sup>	joint length	21,2 m	temp.	19 °C	humidity	28%	atm. pressure	1013hPa
---------------	--------------------	--------------	--------	-------	-------	----------	-----	---------------	---------

**Tab. 7 Air permeability Fixed light 2 positive test pressure**

Air flow		Value of air permeability at pressure, Pa							
		50	100	150	200	250	300	450	600
overall	m <sup>3</sup> /h	2,6	5,2	6,3	7,3	9,9	11,3	17,7	20,5
in relation to joint length	m <sup>3</sup> /hm	0,12	0,25	0,30	0,34	0,47	0,53	0,84	0,97
in relation to surface	m <sup>3</sup> /hm <sup>2</sup>	0,24	0,48	0,58	0,67	0,91	1,03	1,62	1,88
air inf. coefficient , a	m <sup>3</sup> /(mhdaPa <sup>2/3</sup> )	0,04	0,05	0,05	0,05	0,05	0,06	0,07	0,06

**Tab. 8 Air permeability Fixed light 2 negative test pressure**

Air flow		Value of air permeability at pressure, Pa							
		50	100	150	200	250	300	450	600
overall	m <sup>3</sup> /h	3,9	5,8	7,1	9,2	10,1	11,9	14,5	17,3
in relation to joint length	m <sup>3</sup> /hm	0,18	0,27	0,34	0,43	0,48	0,56	0,69	0,82
in relation to surface	m <sup>3</sup> /hm <sup>2</sup>	0,36	0,53	0,65	0,84	0,92	1,09	1,33	1,58
air inf. coefficient , a	m <sup>3</sup> /(mhdaPa <sup>2/3</sup> )	0,06	0,06	0,06	0,06	0,06	0,06	0,05	0,05

**Tab. 9 Air permeability Fixed light 2 numerical average**

Air flow		Value of air permeability at pressure, Pa							
		50	100	150	200	250	300	450	600
overall	m <sup>3</sup> /h	3,3	5,5	6,7	8,3	10,0	11,6	16,1	18,9
in relation to joint length	m <sup>3</sup> /hm	0,15	0,26	0,32	0,39	0,47	0,55	0,76	0,89
in relation to surface	m <sup>3</sup> /hm <sup>2</sup>	0,30	0,50	0,61	0,76	0,92	1,06	1,47	1,73
air inf. coefficient , a	m <sup>3</sup> /(mhdaPa <sup>2/3</sup> )	0,05							

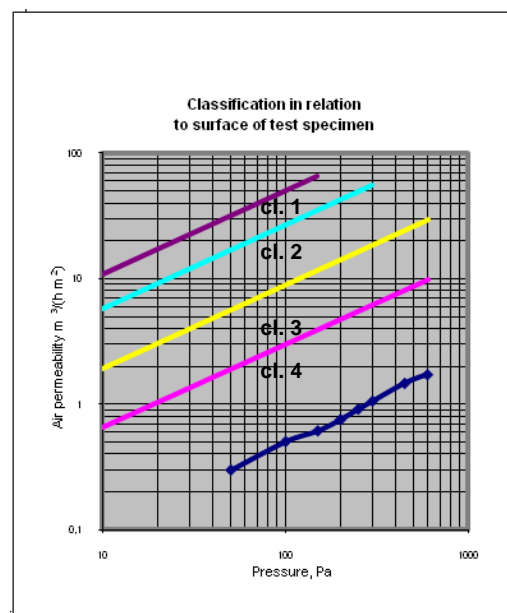
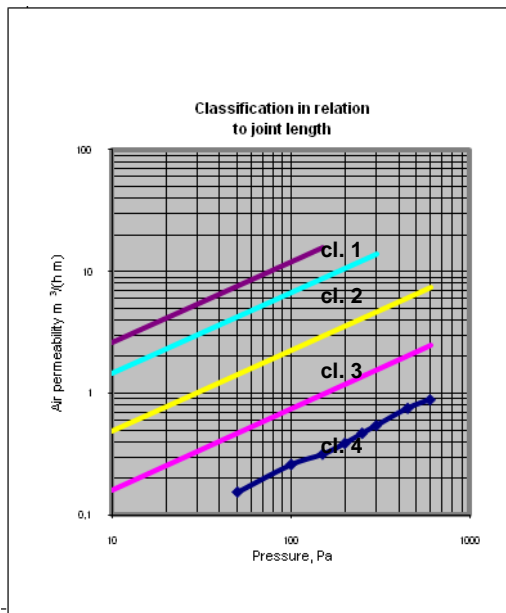

Classification in relation to joint length	Class 4
Classification in relation surface of test specimen	Class 4
<b>PN-EN 12207:2001 overall classification</b>	<b>Class 4</b>

### 3.5 Impact resistance

The test was carried out in accordance with the PN-EN 13049:2004.

Impact were carried out inside and outside – Fixed light infilling consisted of 6/16/33.1 insulating glass unit .

Height of impact – 450mm. After test no visible changes were observed.

The spacing of impact resistance points is presented on figure no. 7.

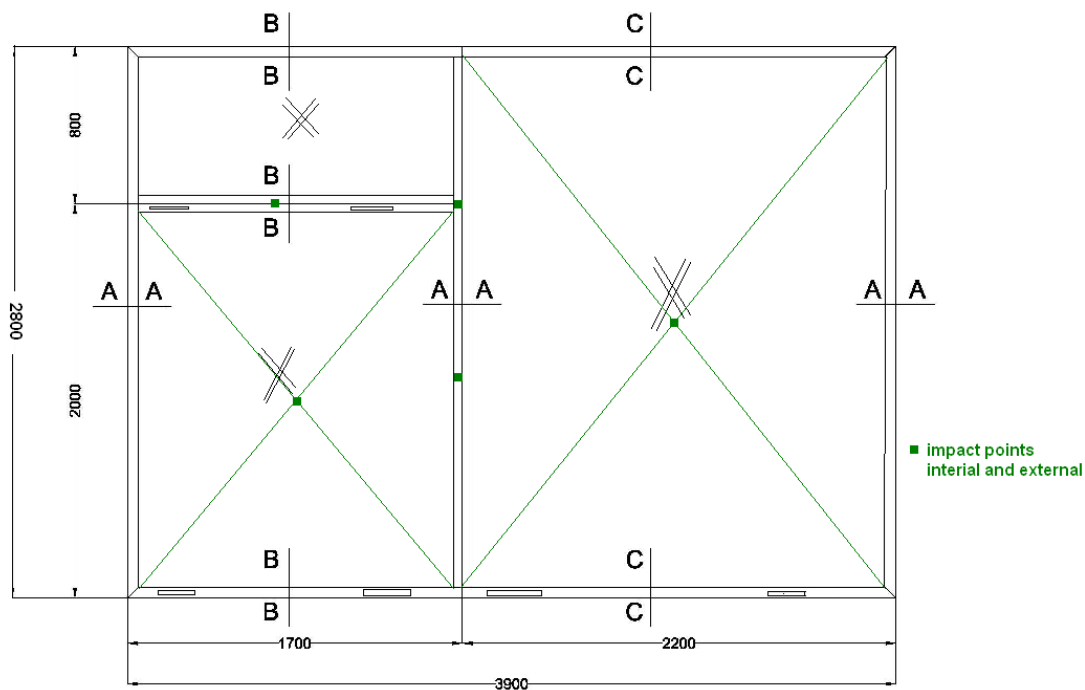



Fig. 7 Spacing of impact points

## 4 Classification

On the base of test results the classification is presented in table no. 10.

Tab. 10 Classification of the tested Fixed light ECOFUTURAL EF with additional mullion

Properties	Classification	Classification standards
Air permeability	class 4	PN-EN 12207:2001
Watertightness	class 9A (600Pa)	PN-EN 12208:2001
Resistance to wind load	class B4 (1600Pa)/ C3 (1200Pa)	PN-EN 12210:2001
Safety test	2400Pa/1800Pa	
Impact resistance	class 3 (450mm)	PN-EN 13049:2004

Responsible for the test: <b>Msc eng. Marzena Jakimowicz</b> 	Authorizing Person <b>dr eng. Krzysztof Kuczyński</b> 
<b>Warsaw 28.06.2011</b>	
<b>Testing Laboratory declares that test results relate only to the object under test. Test Report should not be reproduced without a written permission of Testing Laboratory in any other form than as a whole. Test Report is not the document admitting object to trade and general application in building industry.</b>	

Head of Testing Laboratory  
dr eng. Paweł Sulik

  
.....